

**DESTINATION** Cross country, Gravel.

### GUIDELINE

Periodically clean hub internals (every 6-12 months in normal and dry conditions, every 3 months in wet conditions and always before leaving the wheel un-used for more than 1 month) see Level1 instructions next page.  
Never use high-pressure spray washing directly on hubs. Clean hubs externally with warm water and soap.

**WARNING** Avoid the following errors that will seriously damage the hub internal parts (immediately or in a very short time):

- Too much greasing.
- Uncorrect positioning of grease.
- Wrong grease type (Lithium grease is the most dangerous).
- Micro Tuner way off its correct range (this increases also the clearance between engagement teeth)
- Never couple new engagement parts in contact with worn-out ones.

Once engagement teeth got damaged by a slow / un-free movement of the Floating Ring there is no other way than replace the entire Freewheel assembly.

### BEARING PRELOAD SET-UP:

Optimal bearing preload is important for a long bearing life. Incorrect bearing preload can damage bearings and freewheel parts additionally decreases hub performance.

Micro Tuner comes pre-adjusted from the factory. Do not modify its position if not necessary.

### WARNING

- Riding with a too-tight Micro-Tuner reduce bearing life and performance.
- Riding with a loosen Micro-Tuner may causes an uncomplete freewheel engagement and damages mechanism permanently.

### Checking

Before modifying bearing preload carefully check the complete wheel as follows:

- 1) Gently push Axle from right side using a plastic mallet.
- 2) Install wheel into dropouts and normally lock skewer.
- 3) Check there is no play at rim diameter.
- 4) Leave wheel free to completely stop spinning and carefully control latest instants of movement. Stopping should be very smooth.

### Preload Tuning

If necessary fine tune as follows.

- 1) Gently push Axle from right side using a plastic mallet.
- 2) Install wheel into dropouts and normally lock skewer.
- 3) If you feel play at the rim turn in Micro Tuner (clockwise). Use a 21mm wrench, very delicate torque and manners.
- 4) Unscrew Micro Tuner for ca 1/4 of turn to release excessive preload on bearing balls and achieve max rolling smoothness.
- 5) Repeat Preload Checking and eventually slightly correct it.
- 6) The optimal bearing preload cancels play at the rim without affecting rolling smoothness.

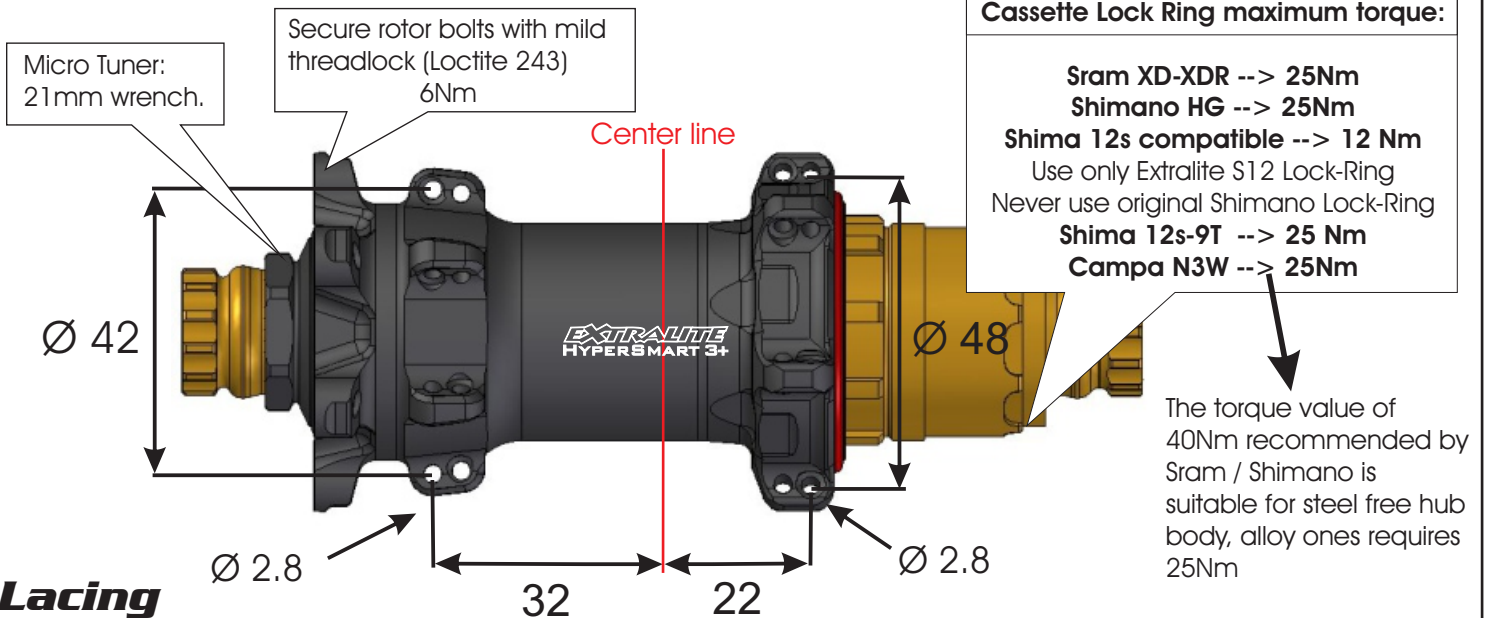

### Lacing

Respect specific lacing pattern (see drawing).  
See [www.extralite.com](http://www.extralite.com) to find pre-calculated spoke lengths.  
Make sure hub is properly assembled and adjusted before lacing.

### Hub maximum spoke tension:

**Drive Side: 130 Kgf**

**Left Side: consequently**

In any case never exceed the maximum tension recommended by rim manufacturer.

Do not laterally over-push Axle at the spoke stretching procedure.  
Excessive lateral load may damage external bearings.

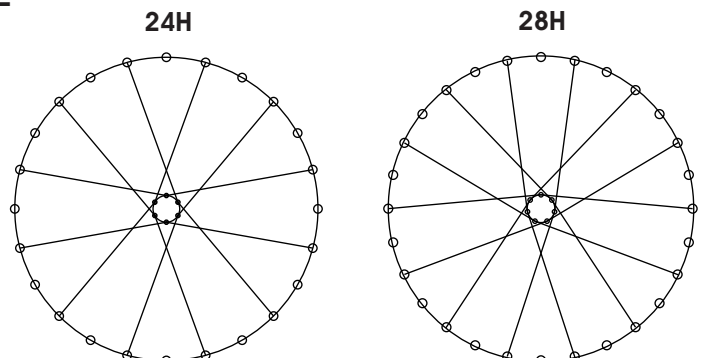

## Maintenance (level 1) Complete cleaning

Follow maintenance steps on a clean and well illuminated table since you'll have to handle tiny springs and delicate parts.

Even small debris can compromise freewheel engagement mechanism. Water and moisture stagnant inside hub will damage bearings in few weeks.

### Disassembling

- 1) Hold Left Axle End with a 17mm closed wrench.
- 2) Unscrew Right Axle End with another 17mm closed wrench.
- 3) Pull Freewheel Body and remove it.
- 4) Extract Bearing Spacer.
- 5) Remove Lip Seal from Hub Body.
- 6) Remove Floating Ring from Hub Body, you'll find 3 tiny springs on its back side.
- 7) Push out Axle Assembly and completely extract it from disc side.

### Cleaning

- 8) Clean all parts (Do not use aggressive solvents).
- 9) Clean very carefully Internal Splines, Floating Ring and Freewheel Teeth.

### Hubshell Splines Check - IMPORTANT!

Once hub-shell internal is perfectly clean check well that every spline corner (clockwise corners) is still well square and flat.

In case your hub has worn-out splines and you are not sure about it contact us [info@extralite.com](mailto:info@extralite.com) providing clear close-up photo.

### Potential risk

When riding HyperHubs with dirt inside the hard particles of sand can badly grind the hubshell splines. Shortly the sand wears the hub-shell splines till the "floating ring" will not move freely anymore. This easily causes an uncomplete freewheel engagement and damages permanently the newly installed freewheel parts. In this case replacing "floating ring" and/or "Freewheel body" does not solve. The expensive hub-shell should be replaced (or eventually sent back for re-sharpening).

For more detailed information check HyperHubs Tips on [extralite.com](http://extralite.com)

### Lubrification and reassembling

**Warning:** use only very soft density grease as original Alugrease Super. Never use medium-dense or sticky grease since can slow down Floating Ring movement, this can destroy the freewheel mechanism! Chemical additives may damage O-rings and Lip Seal.

- 10) Grease Axle on bearing contact areas.
- 11) Fill up Micro Tuner internal face with soft grease.
- 12) Insert Axle Assembly from disc side.
- 13) Insert Bearing Spacer.
- 14) Oil Internal Splines of Hub Body with 1cc w10-40 motor oil, do not apply grease here.
- 15) Apply a minimal amount of grease into spring fitting holes on Floating Ring back side, then carefully insert the 3 springs.
- 16) Insert Floating Ring into Hubshell Internal Splines.
- 17) Fully snap in Lip Seal (uncomplete/unaligned inserting voids its seal function).
- 18) Check again that the 3 springs are in their correct position.
- 19) Check that Floating Ring moves freely and quickly (press and release).
- 20) Apply 1cc of soft grease onto Freewheel Engagement Teeth.
- 21) Insert Freewheel, do not pinch Lip Seal.
- 22) Tighten Right Axle End at 9 Nm.
- 23) Check Preload Tuning (see chapter).
- 24) Install External OR (27x1.5 oiled) between Micro Tuner and bearing.

