

Hyper3 MTB 'Hemi' Freewheel Kit

Installation manual

Compatible with HyperBoost3 R - HyperSmart3 R

WARNING: Execute these operations only on a well clean and well illuminated table, you'll have to handle delicate internal parts and tiny springs, even small debris can compromise the freewheel engagement mechanism. Carefully follow maintenance instructions step by step. Schedule periodical cleaning and lubrication sessions; water and moisture stagnant inside hub will damage bearings in few weeks.

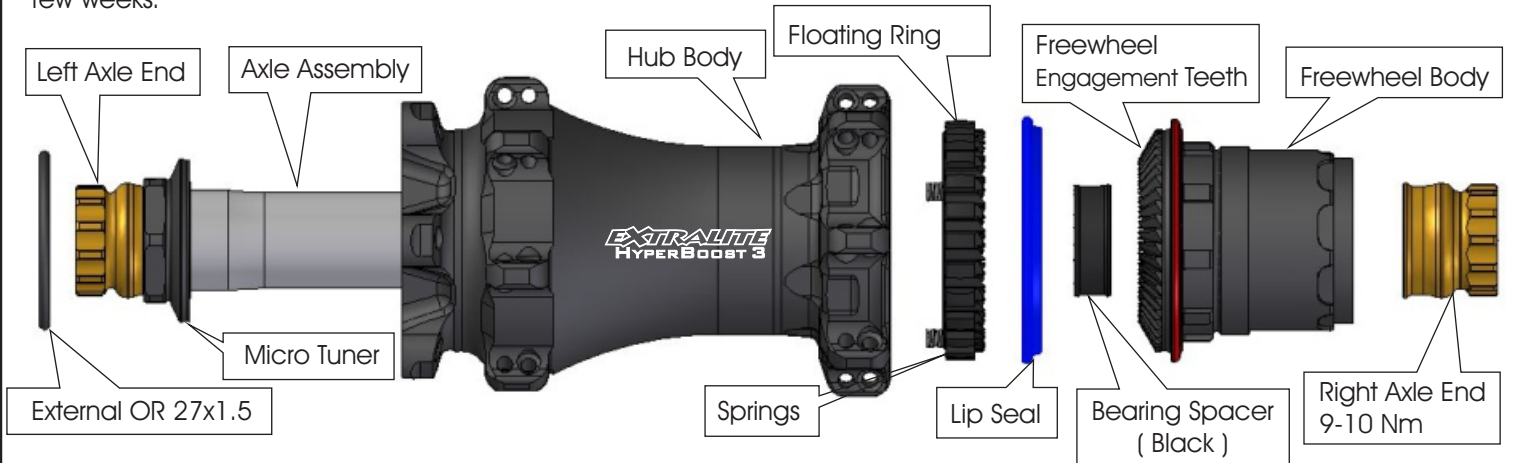

Disassembling

- 1) Hold Left Axle End with a 17mm closed wrench.
- 2) Unscrew Right Axle End with another 17mm closed wrench.
- 3) Pull Freewheel Body and remove it.
- 4) Extract Bearing Spacer.
- 5) Remove Lip Seal from Hub Body.
- 6) Remove Floating Ring from Hub Body, you'll find 3 tiny springs on its back side.
- 7) Push out Axle Assembly and completely extract it from disc side.

Cleaning

- 8) Clean all parts (Do not use aggressive solvents).
- 9) Clean very carefully all Internal Splines.

Warning: even one small debris can void freewheel engagement.

Warning: carefully check hubshell Splines (see below).

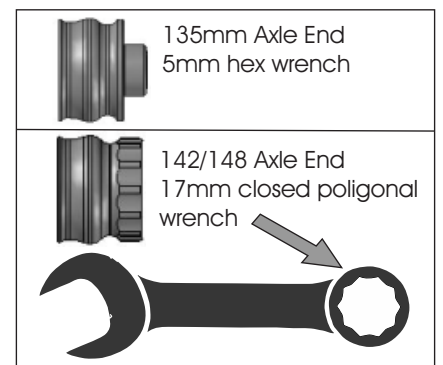

Hubshell Splines Check - IMPORTANT!

Clean and degrease perfectly hubshell internal splines, all of them. Once hub-shell internal is perfectly clean check well with eye magnifier all the 24 splines, see image.

Every spline corners (clockwise corners) should be well square and flat.

In case your hub has 24 used splines and you are not sure about it contact us info@extralite.com providing clear close-up photo.

Potential risk

When riding HyperHubs with dirt inside the hard particles of sand can badly grind the hubshell splines. Shortly the sand wears the hub-shell splines till the "floating ring" will not move freely anymore. This easily causes an uncomplete freewheel engagement and damages permanently the newly installed freewheel parts. In this case replacing "floating ring" and/or "Freewheel body" does not solve. The expensive hub-shell should be replaced (or eventually sent back for re-sharpening).

For more detailed informations check HyperHubs Tech Tips on www.extralite.com

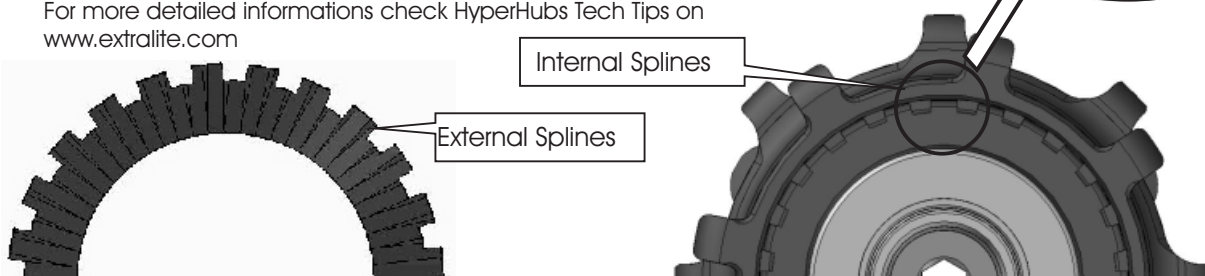

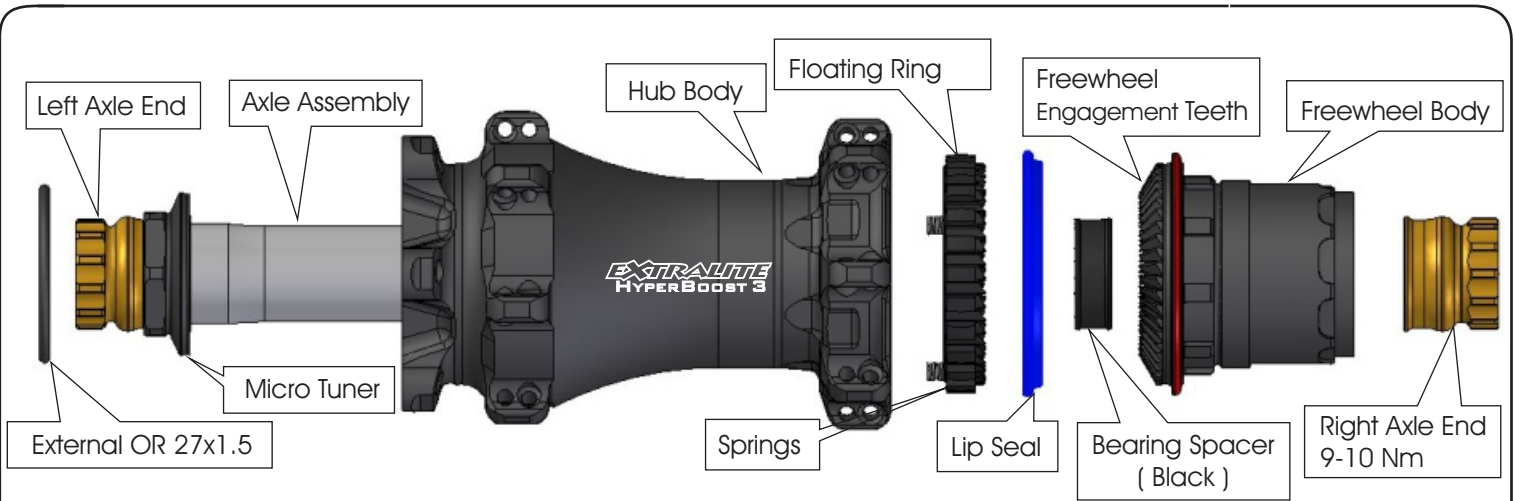

Lubrication and reassembling

Warning: use only very soft density grease as original Alugrease Super.

Never use medium-dense or sticky grease since can slow down Floating Ring movement, this can destroy the freewheel mechanism! Chemical additives may damage O-rings and Lip Seal.

- 1) Grease Axle on bearing contact areas.
- 1) Fill up Micro Tuner internal face with soft grease.
- 2) Insert Axle Assembly from disc side.
- 3) Insert Bearing Spacer.
- 4) Oil Internal Splines of Hub Body with 0.5cc w10-40 motor oil, do not apply grease here.
- 5) Apply a minimal amount of grease into spring fitting holes on Floating Ring back side, then carefully insert the 3 springs.
- 6) Insert Floating Ring into Hubshell Internal Splines.
- 7) Fully snap in Lip Seal (uncomplete/unaligned inserting voids its seal function).
- 8) Check again that the 3 springs are in their correct position.
- 9) Check that Floating Ring moves freely and quickly (press and release).
- 10) Apply 0.5cc of soft grease onto Freewheel Engagement Teeth.
- 11) Insert Freewheel, do not pinch Lip Seal.
- 12) Tighten Right Axle End at 9-10 Nm.
- 13) Check Preload Tuning (see below).
- 14) Install External OR (27x1.5 oiled) between Micro Tuner and bearing.

Preload Tuning

If necessary fine tune as follows.

- 1) Install wheel into dropouts and normally lock skewer.
- 2) If you feel play at the rim turn in Micro-Tuner (clockwise). Use a 21 mm wrench, very delicate torque and manners.
- 3) Unscrew Micro-Tuner for ca 1/4 of turn to release excessive preload on bearing balls and achieve max rolling smoothness.
- 4) Repeat Preload Checking and eventually slightly correct it.
- 5) The optimal bearing preload cancels play at the rim without affecting rolling smoothness.

Warning Incorrect bearing preload can bring to serious damages:

- Too tight --> bearings damage and premature wear
- Too loose --> axial play, permanent freewheel damage

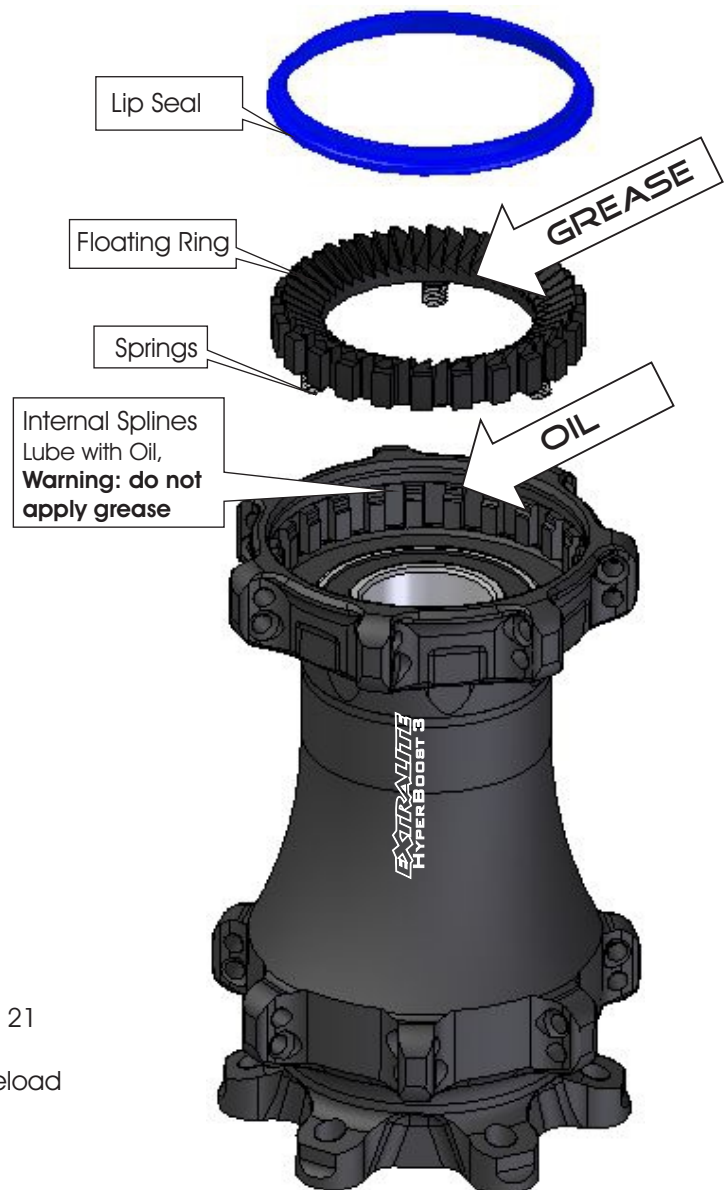

info@extralite.com

EXTRALITE
racing products